

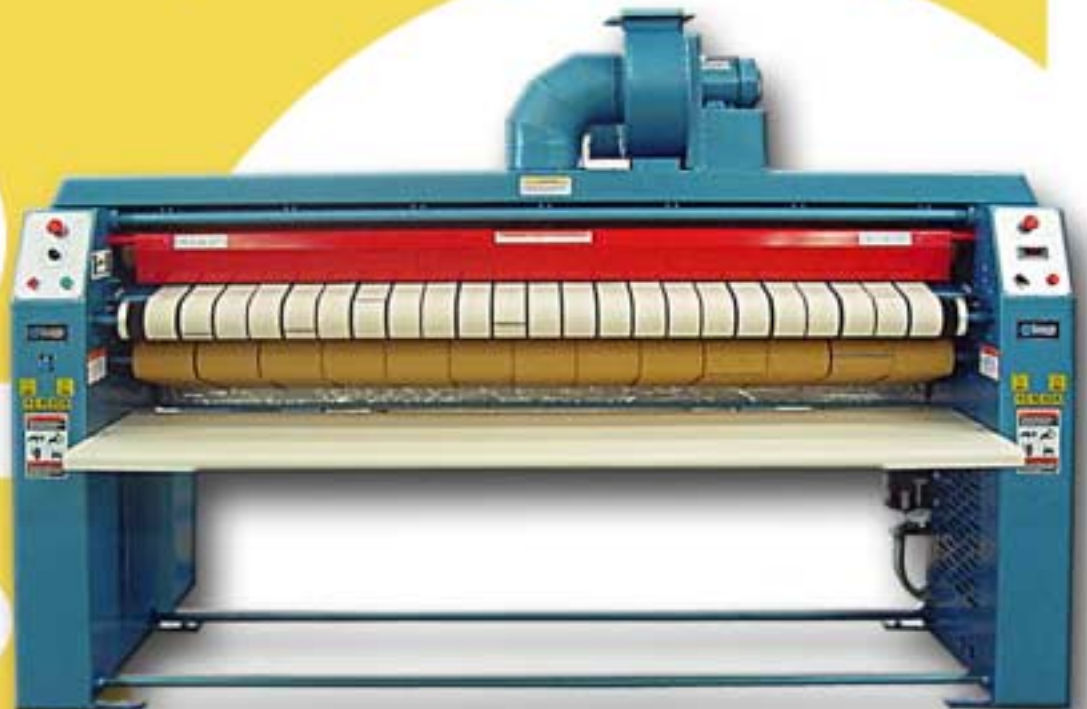

# IP Series

## Ironer Compact Compact

14 " x 78 "  
Heavy Duty  
Compact Flatwork Finisher





# IP Series

The IP Series - Compact Economy Ironers for General Laundry Applications Demanding High Standard of Linen Quality

Economical, Safe and User Friendly at a Surprisingly Affordable Price

The IP series ironers are ideal for small to medium size hotels, restaurants, health care, party rental and dry cleaners. They produce high quality linen finish easy and efficiently. They have high evaporation power and save energy. The frame is built with high quality carbon steel primed and painted for long life. The cylinder is mirror polished and supported by heavy-duty lubricated bearings. A large efficient fan pulls evaporated moisture away from the cylinder. Nomex ironing straps that prevent absorption of moisture while ironing extends the life of all feed components. The compact design occupies very little space as the finished linen is discharged to the front. This return system requires only one operator to iron the linen.



Easy to Use Controls and a High Efficiency Inverter Drive for Flexibility

The IP series is equipped with a simple-to-use control that provides precise temperature regulation. The temperatures are shown on a digital readout. The electronic temperature control provides for adjustment of the ironing temperature at any time during operation. A standard high efficiency variable speed inverter controls the speed in an extended speed range to suit today's wide variety of fabrics and moisture retention. The speed can be adjusted at any time during operation. The variable speed drive provides a soft start that reduces the stress on drive components including sprockets bearings, shafts and chains.



Highest Level of Safety

Quality design ensures conformity to world safety standards. The control is simple yet versatile and has all the safety features that are required to protect the machine and the operator. Features such as electrical circuit protection, emergency stops, safety labels and hand guard with double safety across full width of ironer create peace of mind and long life with less maintenance. Environmentally safe temperature resistant textile padding and straps are used. A full size canopy with a powerful exhaust fan (outside for easy cleaning) is provided to optimize vapor evaporation and combustion by-products (gas heated models). A fully enclosed back keeps the heat inside the ironer thus reducing the radiant temperature while saving energy.

# Compact Professional Economy Ironers

## The Benefit of Ironing and Total Solutions from B&C

Discover the affordable alternative and enjoy quality, reliability and trouble free operation. Several factors can significantly affect the laundry equipments performance and operational throughput as well as the quality of the linen being cleaned and finished in the laundry process.

Using high-speed washer-extractors in combination with ironers from B&C Technologies improves production and increases quality. The most efficient way of removing moisture from linen is high extraction and ironing. Our ironers are built to handle the linen direct from our washers.

This is the most economical way of producing high quality work at lowest cost, as it will save energy, time and labor. In addition the capital expenses for B&C quality ironers are significantly lower making it the best for less. Our ironers are designed for simplicity without complicated controls and devices that can go wrong and stop production.

Discover the features and the value of ironers and other products from B&C. We have an ironer and products for any laundry application, from a family dry cleaning-laundry operation to a large industrial high productivity operation. One stop purchase for your laundry equipment needs will benefit you most.

Our ironers will provide the finest quality. There is no substitute for the appearance and feel that only crisply ironed table linen, napkins, pillowcases or sheets can provide. Ironed linen conveys a message of first class quality and cleanliness. Linen that is only tumble dried often gives the impression that it has already been used by a previous guest.

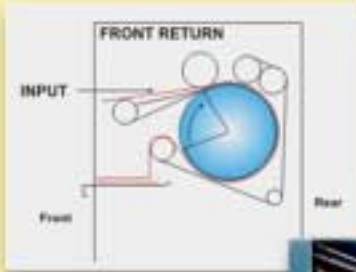

## Additional Features :

- Powerful exhaust blower
- Highly polished heated cylinder for excellent finish quality
- Digital electronic temperature control
- Padding and ribbons of high temperature resistant Nomex
- Padded compression roll
- Easy access to controls
- Easy removable panels
- Safety finger bar across full width of ironer
- Heavy duty painted steel frame
- Safety and warning labels
- Built in active electrical and mechanical safety devices
- Rear of ironer fully enclosed for heat encapsulation
- Laminated and protected return table

# Specifications

MODEL	US	Metric	IP1478
Number of Rolls	roll		1
Roller Diameter	Inch	mm.	14 (355.6)
Working Width	Inch	mm.	78 (2000)
Speed Range	ft/min	M/min	6-36 (1.8-11)
<b>OVERALL DIMENSIONS :</b>			
A - Width	Inch	mm.	98.5 (2500)
B - Depth	Inch	mm.	26.4 (670)
C - Height	Inch	mm.	65 (1650)
D - Canopy Height	Inch	mm.	13.4 (340)
<b>AIR SYSTEM :</b>			
Air Flow	Cfm	Cmm.	1080 (30.6)
Exhaust Duct	Inch	mm.	8 (203.2)
<b>MOTOR :</b>			
Drive Motor	HP	kW	0.5 (0.37)
Blower Motor	HP	kW	0.5 (0.37)
<b>ELECTRICAL REQUIREMENT :</b>			
Power Source	220V, 380V, 440V / 220V, 415V / 3Ph		
Frequency	50/60 Hz		
<b>STEAM :</b>			
Steam Consumption	BHP		1.8
Steam Pressure	psi	kgf/cm <sup>2</sup>	90-125 (6.2-8.6)
Steam Inlet	Inch	mm.	3/4" (19.05)
Steam Outlet	Inch	mm.	1/2" (12.7)
<b>GAS :</b>			
Heat Input	Btu/hr		142290
Gas Inlet	Inch	mm.	1/2" (12.7)
<b>WEIGHT AND SHIPPING :</b>			
Net Weight	Lbs.	Kg.	1051 (477)
Domestic Shipping Weight	Lbs.	Kg.	1162 (527)

Specification and Design subject to change without notice  
Additional options : Consult factory or distributor

## Standard Features :

- Steam, Gas or Electrical heating
- Gas heated models for Natural or LP gas
- Variable speed drive with soft-start
- Electronic temperature control with digital readout
- Jog forward/reverse
- Full exhaust canopy with external blower
- Electrical and mechanical protection devices
- Three phase electrical service
- Highly polished heated cylinder

## Optional Features :

- Single phase electrical service
- Chromed Cylinder

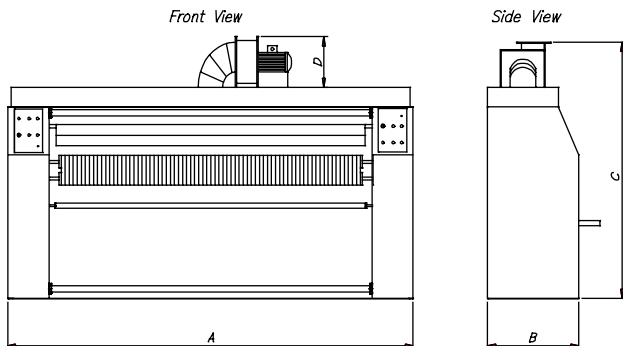

Conforms to all applicable US and Canadian safety standards.

**B&C Technologies**  
Panama City, FL  
Phone: 850-249-2222  
FAX: 850-249-2226  
www.bmctechnologies.com  
sales@bmctechnologies.com